

Ford 10R140

TCC Signal Damper Piston Kit

Part No.
105740-07K

- Piston
- Sleeve
- Spring
- O-Rings (2) 1 Extra

Patent No. 12,129,922

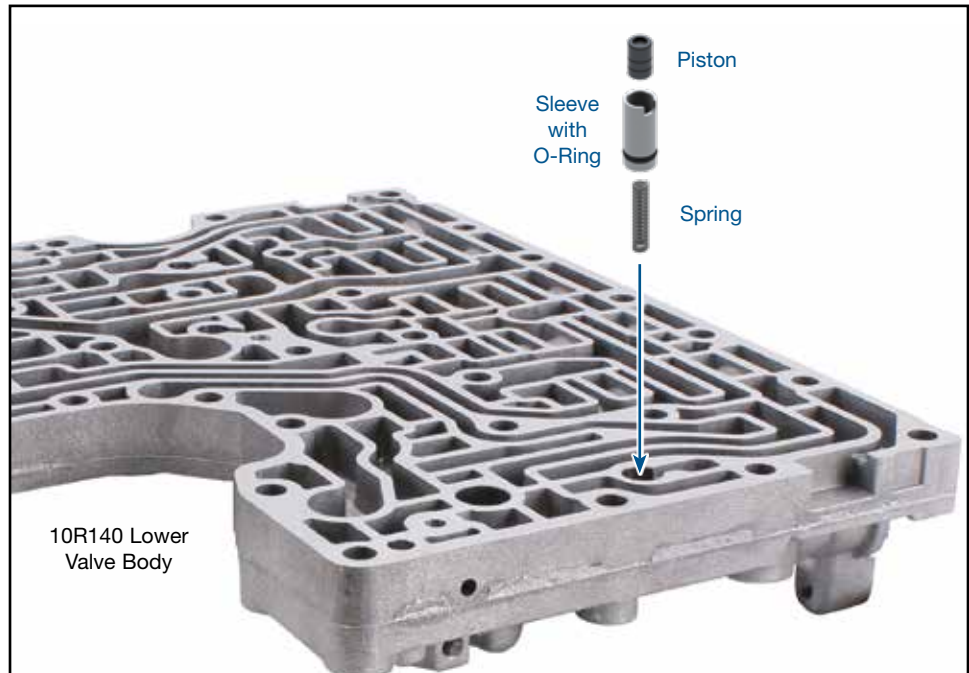

1. Disassembly

Remove and discard the OE piston and spring.

2. Installation & Assembly

- a. Be certain all debris has been removed from valve bore and valve body.
- b. Install O-ring into groove of Sonnax sleeve. Lubricate O-ringed sleeve with Sonnax Slippery Stick **O-LUBE**. Roll on bench to size O-ring into groove.
- c. Install Sonnax spring into the Sonnax piston/sleeve assembly through the bottom hole.
- d. Install Sonnax piston/sleeve assembly and Sonnax spring into the bore. The sleeve bottom extrusion should insert into the exhaust hole at the bottom of the bore. The sleeve top cutout should line up with the channel at the top of the bore (**Figure 1**).

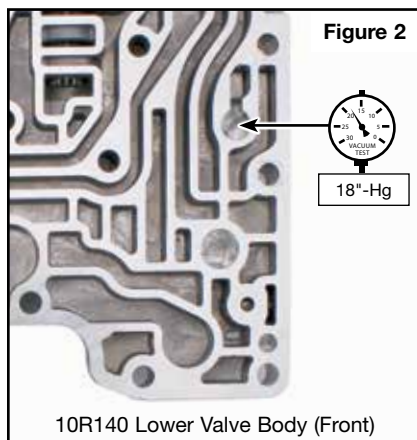
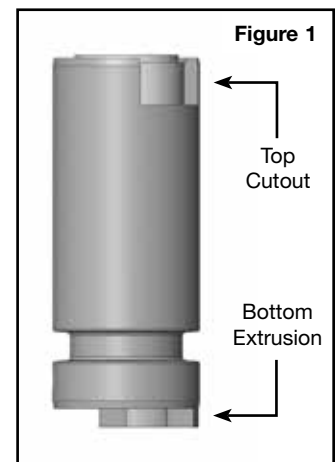

3. Final Testing

Vacuum testing at the port(s) indicated holds the recommended minimum 18 in-Hg (**Figures 2 & 3**).

