

Oversized Pressure Regulator & Boost Valve Kit



Part No.
104520-16K

- Pressure Regulator Valve
- Spring
- Boost Valve
- Boost Sleeve
- Checkball

Tool Kit



Part No.
F-104520-TL7C

- Reamer
- Reamer Jig
- Guide Pin

NOTE: Sonnax "F-Tool" kits designed to service a specific bore require the VB-FIX, a self-aligning valve body reaming fixture. More information and instructions can be found online at www.sonnax.com.

Required

Oversized Pump Base Plate
VB-06



NOTE: Use of the VB-06 is required with the VB-FIX reaming fixture for this installation unless the stator support shaft is removed from the pump body.

GM 6L45, 6L50, 6L80, 6L90

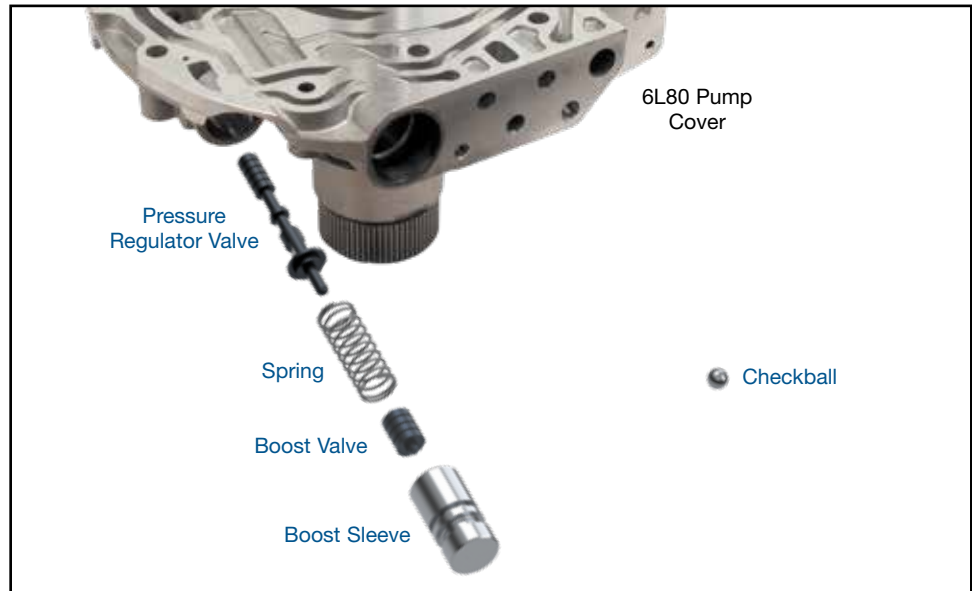

NOTE: In GM 6L45, 6L50, 6L80 and 6L90 units the pressure regulator valve and boost assembly are located in the pump cover. Transmission must be removed from the vehicle to access pump and replace the pressure regulator valve.



NOTE: Pump must be removed to install this kit. Use of the VB-06 is required with the VB-FIX reaming fixture for this installation unless the stator support shaft is removed from the pump body.



NOTE: If you are rebuilding a pump that has a balance port drilled between the cup plug bore and the balance port shown in **Figure 1** with a circle and asterisk, you will need to take a center punch andpeen this port shut.

1. Disassembly

- Remove OE pressure regulator valve train from the pump body.
- Save OE retaining pin and boost valve spring for reuse and discard remainder of the OE valve train.

2. Bore Reaming

Ream pressure regulator bore (for reaming instructions/reamer care, please visit www.sonnax.com). Sonnax reaming tool kit F-104520-TL17C and VB-FIX are required for this operation.

3. Plug OE Orificed Cup Plug

- Locate OE balance feed orificed cup plug.
- Place Sonnax 1/8" aluminum checkball into OE orificed cup plug. Drive checkball into cup plug with appropriately sized punch. Stake cup plug to prevent checkball displacement (**Figure 1**).
- Clean bore thoroughly, removing all debris and chips.

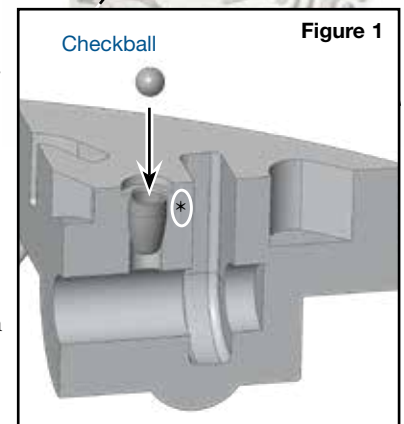
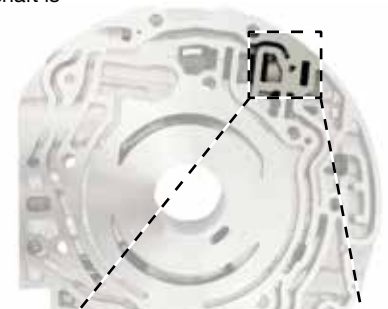

4. Installation & Assembly

- a. Install Sonnax pressure regulator valve.
- b. Install Sonnax outer spring.
- c. Reinstall OE boost valve spring.
- d. Install Sonnax boost valve and sleeve.
- e. Reinstall OE retaining pin.

5. Vacuum Test

Vacuum testing at the port indicated holds the recommended minimum 18 in-Hg (**Figure 2**).

